

Coated Bentofix® NSP X-types

Geosynthetic Clay Liner Installation Guideline NAUE GmbH & Co. KG



Contents	Page
1. Scope	1
2. Quality Statement	2
3. Packaging	2
4. Labeling	2
5. Roll Imprint	2
6. Plant Storage	2
7. Transportation to Site	2
8. Unloading Procedures	2
9. Storage on Site	3
10. Recommended Equipment	3
11. Qualification for Installer	3
12. Weather conditions for Installation	3
13. Subgrade Preparation	4
14. Slopes	4
15. Anchoring	4
16. Installation of Bentofix®	4
17. Overlaps and Seaming	5
18. Attachment Details	7
19. Cover Placement	7
20. Interruptions during Installation	8
21. Repairs	8
22. Inspection	8
23. Hydration of Bentonite	8
24. Special Conditions	8

The following installation recommendation contains general installation guidelines. It is presented as a general format, not as a direct substitute for a project specific specification. In the event of a conflict, the requirement of the project specification will supersede these recommendations. This recommendation does not purport to address all of the safety concerns, if any, associated with its use. It is the responsibility of the user of this guideline to establish appropriate safety and health practices and determine the applicability of regulatory limitations prior to use. Further, this installation guideline does not purport to establish specific procedure for all climatic, geographical, hydraulic, or topographical conditions that may exist at a site. Appropriate installation procedures under atypical field conditions should be modified as necessary to maintain the integrity of the GCL and adjacent components.

The information contained herein has been compiled by NAUE GmbH & Co. KG, Germany, and is, to the best of our knowledge, true and accurate. There is no implied or expressed warranty. Final determination of suitability for use contemplated is the sole responsibility of the user. This information is subject to change without notice. NAUE makes no warranty of any kind and accepts no responsibility for the results obtained through this installation guideline or for the correctness of the GCL use in an application. For further information or questions please consult the specifier, designer or NAUE GmbH & Co. KG. The information contained herein is the best to our knowledge, true and accurate. This installation guide is subject to changes without prior notice.

1. Scope

1.1 Bentofix® geosynthetic clay liners (GCLs) are needle-punched, reinforced composites that combine two durable geotextile outer layers and a uniform core of high-swelling powder sodium bentonite clay. This construction forms a shear resistant hydraulic barrier with self-sealing characteristics.

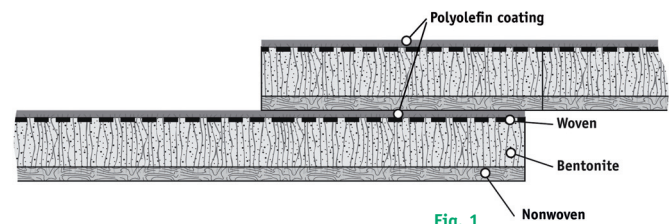

Fig. 1
Typical overlap of Bentofix® NSP X-types

1.2 Additionally a polyethylene (PE) coating is extruded during the manufacturing process directly on to the slitfilm woven side, to ensure a durable bond without any additional adhesive (fig. 1), resp. with an overlap tape (fig. 2).

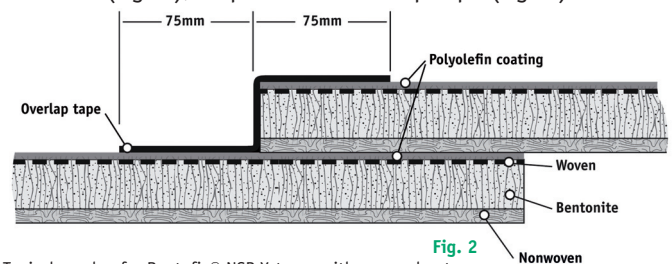

Fig. 2
Typical overlap for Bentofix® NSP X-types with an overlap tape

1.3 The subbase, the Bentofix® GCL as well as the minimum 300mm thick cover soil make the sealing system. Bentofix® GCLs are a sealing element and are not designed to absorb tensile strengths.

1.4 Bentofix® is produced following strict ISO 9001 quality control procedures. Failure to follow good practice may result in the unnecessary failure of the geosynthetic in a properly designed application.

1.5 This installation guideline is applicable for all Bentofix® NSP X-types with an additional PE coating barrier.

1.6 This Bentofix® installation guideline is not applicable for underwater installation applications.

1.7 This guideline must be present to the installer and the responsible site engineer.

2. Quality Statement

2.1 NAUE GmbH & Co. KG as the inventor of needle-punched GCLs in 1987 is dedicated to continuous quality. This commitment begins with the manufacture of the Bentofix® Geosynthetic Clay Liner (GCL) material and its components (as well as the quality control of these and their components), and continues until our customer has accepted the GCL.

2.2 NAUE GmbH & Co. KG is fully ISO 9001 (2008) registered.

3. Packaging

3.1 Manufactured Bentofix® rolls are usually rolled on cores that have a crushing strength sufficient to avoid collapse or other damage in normal use.

3.2 Bentofix® rolls are wrapped with a protection sheet to avoid effects to the roll due to shipment, water, sunlight or contaminants while being stored, transported or handled.

3.3 In the unlikely case of a damage to the wrapping, the damaged area is either fixed with tape (fig. 3) or is fully replaced.

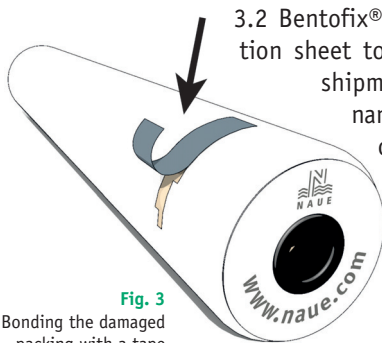

Fig. 3 Bonding the damaged packing with a tape

4. Labeling

On the wrapping of each roll a label with handling guidelines and an identification label (fig. 4) is fixed which includes:



- Name of manufacturer
- Product identification
- Roll dimension
- Unique roll number
- Total mass per unit area

5. Roll Imprint

5.1 Each Bentofix® roll is imprinted either side approx. every 5m during manufacturing with its brand name (fig. 5).

5.2 Each roll of Bentofix® NSP geosynthetic clay liner is printed on the scrim reinforced side (slit-film woven) with the product name and type as well as with a continuous overlap line on each side of the woven, 300mm from the edge. The product imprint lines after unrolling are, if not otherwise requested, faced up against the subgrade.

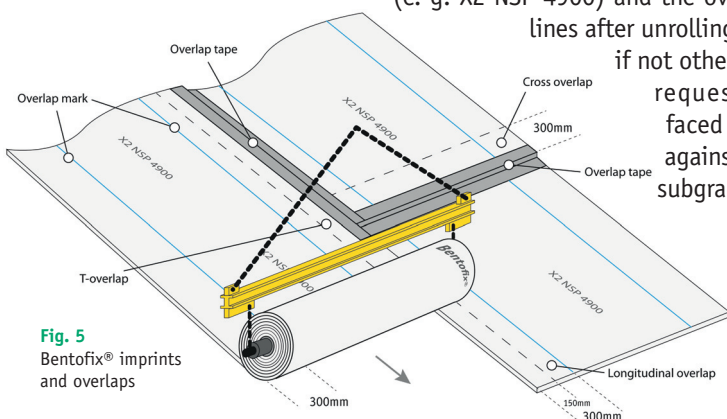

Fig. 5 Bentofix® imprints and overlaps

6. Plant Storage

6.1 Bentofix® rolls are transported in the manufacturing facility by means of stinger bars and are stored so that no damage affects the performance of the material or of the wrapping.

6.2 Bentofix® rolls are stored covered on elevated, dry and smooth ground, which will prevent any damage to the wrapping of the rolls.

7. Transportation to Site

7.1 Bentofix® GCL rolls are delivered to the working area of the site in their original packaging on trucks or in containers. The storage surface should be elevated, dry and smooth, to prevent any damage to the wrapping of the rolls.

7.2 In general supplementary bentonite powder covered with nonwoven strips is needed for overlaps, connections and penetrations with Bentofix® NSP X-types. The necessary amount needed must be ordered prior to shipment. If taping of overlaps is requested, the amount of tape needs to be ordered as well. These are all typically transported such that they do not get wet.

7.3 Before Bentofix® rolls are unloaded it is recommended to identify and verify the shipment and check whether any rolls are damaged. In the unlikely case of damage details should be noted and reported to the forwarding company and the supplier.

7.4 Application dependent it might be applicable to tape water-tight the PE coating of overlaps with a special tape. This must specifically be additionally ordered (fig. 2).

8. Unloading Procedures

8.1 As with any lifting or loading operations, appropriate safety equipment should be employed and proper safe handling methods practised. This includes an appropriate and firm subbase for the vehicle and the Bentofix® storage. The party responsible for unloading the Bentofix® GCL should contact the manufacturer prior to shipment to determine the correct unloading methods and equipment if different from the pre-approved and specified methods. Use Appendix B to make notes if necessary.

8.2 The storage area for Bentofix® rolls must follow section 9.

8.3 Lifting the rolls can be accomplished with a 63mm - 75mm outside diameter steel pipe/bar (preferably solid), with a wall thickness capable of providing sufficient beam strength to support the weight of the roll without bending, which is (GCL type dependent) generally between 900 and 1,200kg (for 5m wide Bentofix® GCLs). The core pipe is inserted through the centre core of the Bentofix® roll. Heavy-duty slings or chains are attached to each end of the pipe, which are then fastened to a spreader bar (fig. 6). A crane, backhoe, front-end loader or any other suitable piece of equipment can then lift the entire assembly.

An all-terrain, extendable boom or fork lift, can be fitted with a special, solid steel pole $\geq 4.0\text{m}$ in length, having an outside diameter of no more than 86mm. The pole is inserted into the core of the Bentofix® roll. The roll should not be fully lifted until the pole extends its full length into the core so that the core does not break.

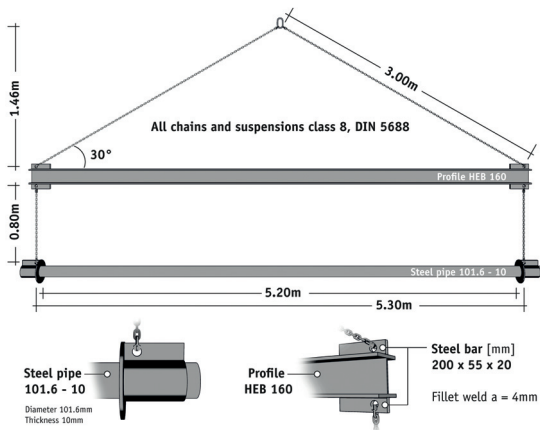

Fig. 6
Installation
spreader bar

This pole has a long reach and is particularly useful for unloading containers or covered vans. Bentofix® GCLs must be supported during

handling to ensure workers safety and prevent damage to the liner and the core pipe (inner diameter approx. 125mm). Under approved and monitored circumstances only, should the rolls be dragged, lifted from one end, lifted with only the forks of a lift truck or pushed to the ground from the delivery vehicle.

8.4 The Construction Quality Assurance (CQA) inspector should verify that proper handling equipment exists which does not pose any danger to the installation crew or risk of damage or deformation to the liner material itself.

8.5 Additional handling equipment is described below:

Spreader Bar Assembly - A spreader bar assembly shall include both a core pipe or bar and a spreader beam. The core pipe shall be used to uniformly support the roll when inserted through the GCL core while the spreader beam will prevent chains or straps from chafing the roll edges.

Stinger - A stinger is a rigid pipe or rod with one end directly connected to a forklift or other handling equipment. If a stinger is used, it should be inserted to its full length into the roll to prevent excessive bending of the roll when lifted.

Roller Cradles - Roller cradles consist of two large diameter rollers spaced approximately 75mm apart which both support the GCL roll and allow it to freely unroll. The use of roller cradles shall be permitted if the rollers support the entire width of the GCL roll.

Slings - two slings (≥ 70 mm width) with sufficient strength (approx. 1/3rd of the roll width away from the edge), which are fixed to the lifting device, with which (depending on the strength of the slings) one or more rolls can be moved without damaging the GCL or the packaging.

8.6 In the unlikely case of damage to the wrapping, the damaged area is either fixed with tape (fig. 3) or is fully replaced.

9. Storage on Site

9.1 A storage area is required that is flat, dry, and well drained to keep the Bentofix® GCL dry and large enough to store the delivered amount of GCL rolls. The surface should be free of sharp rocks or other objects that could damage the GCL. The storage area must be as close as practical to the work area to minimize on site handling.

9.2 The storage area must be secure to prevent vandalism, theft, and must be such that rolls are unlikely to be damaged by passing vehicles. Rolls of Bentofix® and bentonite for the overlap areas need to be covered with a plastic sheet or tarpaulin until their installation.

9.3 Any rolls that come in contact with moisture while in storage should be examined prior to installation to ensure that subsequent physical damage has not occurred. Physically damaged rolls should be set aside for further examination to determine the plausibility of repair.

9.4 Bentofix® GCLs can be stacked up to five rolls high if stored on site (fig. 7). It must be ensured that rolls cannot move at any time once stacked and stored. If rolls need to be stacked higher please contact NAUE or their representative.

9.5 Arrange storage so that access can be maintained to one or preferably two sides of the stored GCL rolls. Pulling of rolls should be avoided.

9.6 On site delivered bags with bentonite, nonwoven strips and if requested the overlap tapes should also be stored dry and if necessary protected with a waterproof and resistant plastic sheet. It is required to store delivered overlap tapes in a dry environment and in a temperature range of 4°C – 40°C and to avoid direct sunlight.

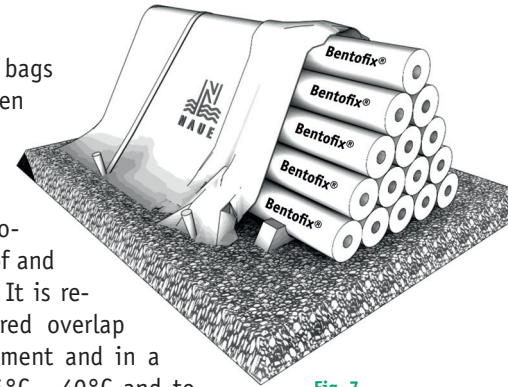

Fig. 7
Bentofix®
storage on site

10. Recommended Equipment

- Approved Vehicles, e.g. excavator
- Bagger
- Spreader bar
- Utility knife
- Trowel
- Bucket
- Shovel
- Marker
- Yardstick
- Pressing roll
- Cleaning cloth
- Iso propyl alcohol

11. Qualification for Installer

11.1 The installation crew must have knowledge of the Bentofix® installation guidelines and be trained on the installation procedure of Bentofix® GCLs.

11.2 It is recommended to note the date of training in the construction journal. Appendix A can be used as a general format.

11.3 NAUE staff or their representative personnel or their representative personel can train installers if requested. Details are to be determined prior to the training.

12. Weather conditions for Installation

12.1 The weather conditions should allow a dry installation of Bentofix® GCLs and the placement of the cover materials.

12.2 The base must fulfill the specification or the requirements as stated in section 13.

12.3 Installation should follow the procedures described in Sections 13 to 19 (incl).

12.4 If the GCL is hydrated (typically $\geq 50\%$ according to DIN 18121) when no confining stress is present, it may be necessary to remove and replace the hydrated material. The project engineer, Construction Quality Assurance (CQA) inspector, and GCL supplier should be consulted for specific guidance if premature hydration is suspected to have occurred.

12.5 If using overlap tapes the weather conditions must ensure a dry and dust free surface.

13. Subgrade Preparation

13.1 The surface upon which the Bentofix® GCL is installed should be smooth and free of debris, roots, sticks, and sharp rocks/boulders larger than 50mm. Site specific compaction requirements should be followed in accordance with the project plans and specifications.

13.2 At a minimum, the level of compaction should be such that installation equipment or other construction vehicles that traffic the area of deployment do not cause significant rutting.

13.3 In applications where the Bentofix® GCL will be subjected to a hydraulic head that exceeds the cover soil confining stress, subgrade surfaces consisting of gravel or granular soils may not be acceptable due to their large void content. For these applications, the top 150mm of the subgrade soil should possess a particle size distribution where at least 80 percent of the soil is finer than 0.2mm with a maximum particle size of 12mm. Directly prior to deployment of the Bentofix® GCL, the subgrade shall be final-graded to fill in any remaining voids or desiccation cracks and proof-rolled to ensure that no sharp irregularities or abrupt elevation changes exist greater than 25mm.

13.4 The surfaces to be lined shall be maintained in this condition, free of standing water.

13.5 If required the subgrade preparation and surface should be inspected and certified by a CQA inspector prior to Bentofix® GCL placement. Upon approval by the CQA inspector, it should be the installer's responsibility to indicate to the engineer any change in the condition of the subgrade that could cause it to be out of compliance with any of the requirements of the project specific specification.

14. Slopes

14.1 In all cases it is required that the responsible designer approves the slope stability analysis of the system.

14.2 On slopes with an inclination larger than 17% (9.65°; 1V:6H) and 3m length it is necessary to install Bentofix® in direction of the slope. In any cases the relative interface friction angles should be confirmed with shear box tests. Cross-overlaps are to be avoided. Should this not be possible, then cross-overlaps have to be in the direction of the water flow (fig. 8; roof tile system).

14.3 If slopes exceed an inclination of 28.6% (16°; 1V:3.5H) hidden anchor trenches in the slope might be applicable and should be approved by the responsible designer.

14.4 If anchor trenches are specified at the top of the slopes, then follow section 15.

14.5 The coated surface of Bentofix® NSP X-types can differ (based on the mass per unit area of the coating) so that interface friction values might differ (see section 14.1)

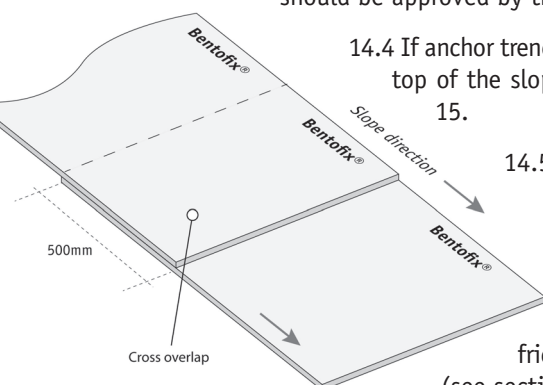

Fig. 8 Overlaps in direction of waterflow (roof tile system)

15. Anchoring

15.1 Bentofix® GCL is typically anchored in a trench on the top of slopes, e.g. around the perimeter of the containment basin to provide the required pullout resistance. In most cases Bentofix® GCLs can be anchored in the same trench as any adjacent geosynthetic liner components (if used).

15.2 Dimensions and location of the trench should be provided in the project drawings or from figure 9. Alternately, the material may be anchored by deploying additional run-out of material past the slope crest.

15.3 The front edge of the trench should be rounded so as to eliminate any sharp corners that could cause excessive stress on the GCL.

15.4 When an anchor trench is required, it shall be excavated no more than two days ahead of GCL placement. This should prevent the trench sides from falling in and requiring re-excavation.

15.5 When the panels are placed in position, the anchor trench must be loosely backfilled or loaded with sandbags immediately.

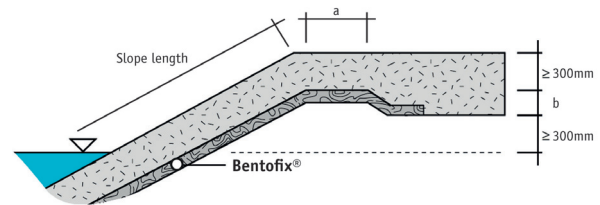

Slope length	a	b
< 10m	≥ 500mm	≥ 500mm
10 - 40m	≥ 800mm	≥ 600mm
> 40m	≥ 1000mm	≥ 800mm

Fig. 9 Anchor trench details

15.6 The appropriate backfill procedures should be in accordance with the project drawings and specifications.

15.7 The lowest point of any anchorage should be minimum 300mm higher than the highest water table, e.g. in a containment application.

16. Installation of Bentofix®

16.1 GCL rolls are to be delivered to the working area of the site in their original packaging.

16.2 As Bentofix® rolls are selected for deployment, the roll labels should be removed and recorded by the installer or the quality control inspector, along with any other pertinent information. Only approved material may be installed (Appendix C can be used to make notes).

16.3 Immediately prior to deployment, the packaging shall be carefully removed without damaging the GCL. If not otherwise ordered, the coated surface will be facing up. Overlap marks on both sides indicate the top side (coated surface).

16.4 The layout and sequence of panel placement is determined by direction of water run-off. Panels are laid out according to the previously approved panel layout drawings, when such drawings are available.

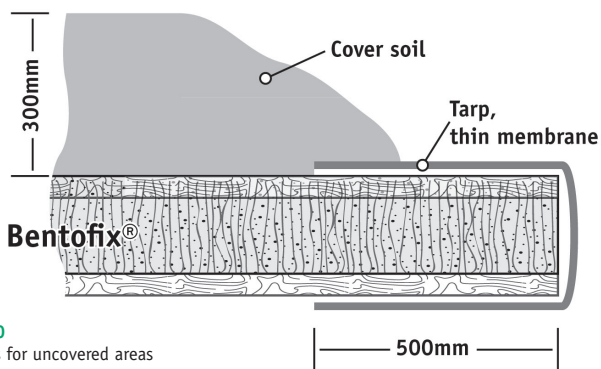

Fig. 10
Details for uncovered areas

16.5 Generally, the installation is started at the top of the slope and at the highest elevation so that any rainfall runs off the lower part of the impoundment, this prevents water from hydrating the GCL.

16.6 When in position, panels are checked for any physical damage.

16.7 All Bentofix® GCL rolls should be installed in a relaxed condition, and be free of wrinkles and folds.

16.8 Rolls of Bentofix® material are unrolled using a front-end loader or other approved handling equipment. A spreader bar (fig. 6) or other approved apparatus is attached to the bucket or the front of the equipment.

16.9 Panels on slopes are placed so that the seam runs parallel to the direction of the slope. Flat areas are laid in no particular orientation, but the panels should be shingled in the down-slope direction to facilitate drainage.

16.10 If required, a smooth piece of geomembrane will be used as a rub sheet to facilitate deployment of other geosynthetic layers. The rub sheet does not need to run the entire length of the slope, only the top crest and first few metres of the slope need to be covered to facilitate deployment. After use, the rub sheet has to be removed.

16.11 No equipment that could damage the GCL shall be allowed to travel directly on the GCL. Acceptable installation, for example, may be accomplished such that the GCL is unrolled in front of the backwards-moving deployment equipment, such as a front-end loader or bulldozer. If the equipment causes rutting of the subgrade, the subgrade must be restored to its originally accepted condition before placement continues.

16.12 Only as much Bentofix® GCL as can be covered by the end of the day should be deployed, or such amount that can be covered in a reasonably short time in the event of precipitation. Uncovered overlap edges should be protected overnight with a plastic membrane (fig. 10) to prevent bentonite hydration. The edges of exposed sheets should be weighted down with sandbags or equivalent ballast, which does not cause any damage to the GCL, to prevent uplift in the event of strong winds.

16.13 In cases where the coating of Bentofix® NSP X-types is positioned on top, it is possible that installed panels can stay uncovered for a longer period. In this case it must be ensured that water cannot enter through the overlaps and the bentonite of installed Bentofix® panels cannot swell due to subgrade moisture over 50% water content. Uncovered sections must be limited to maximum one week.

16.14 Cutting of Bentofix® GCLs may be required at some times, e.g. around penetrations. This can be accomplished by using a sharp utility knife. Frequent blade changes are recommended to avoid damage to the geosynthetic components of the GCL during the cutting process. Removed blades should not be discarded on or under installed Bentofix®.

17. Overlaps and Seaming

17.1 GCL seams are constructed by overlapping their adjacent edges. Care should be taken to ensure that the overlap zone is not contaminated with loose soil or other debris.

17.2 Do not walk on or drive over overlap areas.

17.3 Do not lay identical Bentofix® surfaces over each other (e.g. slit-film woven on top of slit-film woven).

17.4 Seams should be constructed such that they are shingled in the direction of the grade in a manner that prevents the potential for flow entering the overlap zone.

17.5 T-shaped seams (fig. 11) should be reduced to a minimum.

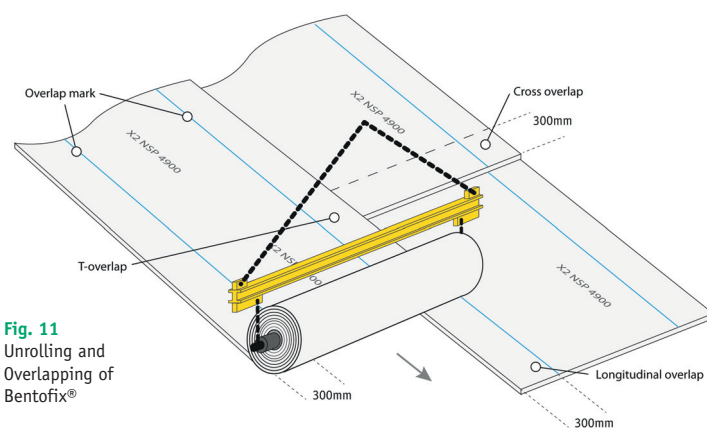

Fig. 11
Unrolling and
Overlapping of
Bentofix®

17.6 Two adjacent laying end overlaps (cross overlaps) are not allowed.

17.7 Overlaps in low points should be avoided.

17.8 Unless otherwise specified, the minimum dimension of the longitudinal overlap should be 300mm. The edge overlap lines of Bentofix® allow the line-up during the unrolling process (fig. 11). End-of-roll overlapped seams should be constructed similarly but the minimum overlap should measure 500mm. Care should be taken to maintain these overlap dimensions at the time of covering, in all climatic conditions.

17.9 To prevent uplift in the event of strong winds, it may be necessary to place sand bags or approved soil material over overlap areas.

17.10 Rolls should be adjusted to smooth out wrinkles or creases between adjacent panels while leaving the proper overlap and be free of wrinkles, folds or "fish-mouths" when covered.

17.11 If the specification does not ask for taping of overlaps supplemental bentonite is needed in the overlap area of Bentofix® NSP X-types (coated woven surface must lay on top). In this case section 17.12 to 17.29 is not applicable.

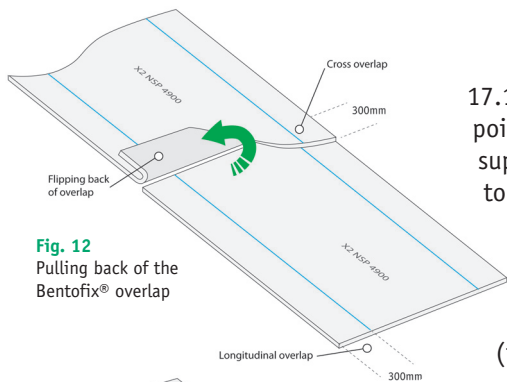

Fig. 12
Pulling back of the Bentofix® overlap

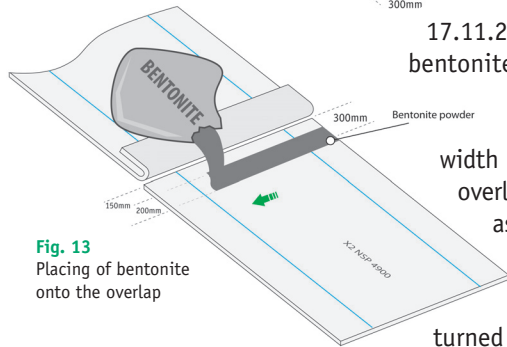

Fig. 13
Placing of bentonite onto the overlap

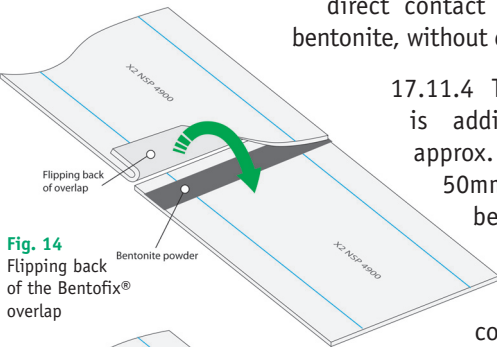

Fig. 14
Flipping back of the Bentofix® overlap

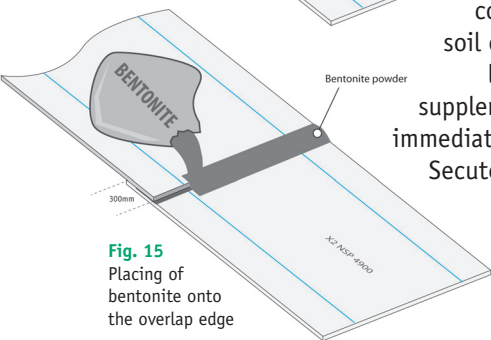

Fig. 15
Placing of bentonite onto the overlap edge

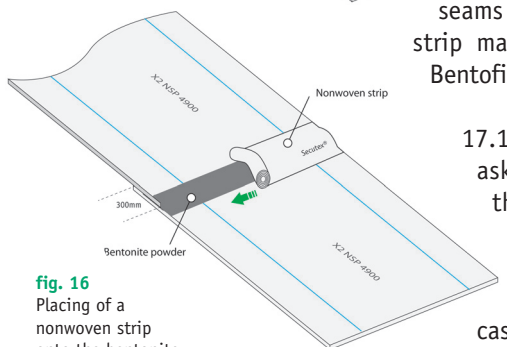

Fig. 16
Placing of a nonwoven strip onto the bentonite at the edge

17.11.1 To have a reference point for the placement of supplemental bentonite, the top side of the underlying Bentofix® roll should be marked. The overlapping Bentofix® may then be flipped back (fig. 12).

17.11.2 The necessary amount of bentonite (approx. 0,6kg/m) shall then be placed onto the overlap area in a width of 200mm (150mm in the overlap area and 50mm in front, as shown in fig. 13).

17.11.3 The flipped back Bentofix® is then turned back (fig. 14), having a direct contact with the supplemental bentonite, without creating any fish mouths.

17.11.4 The edge overlap area is additionally treated with approx. 10 to 20mm thick and 50mm wide supplementary bentonite of approx. 0,4kg/m (fig. 15).

17.11.5 To avoid contamination with loose soil or other debris, the overlap area, especially with supplemental bentonite, should immediately be covered with the Secutex® nonwoven strip and remain in place during the entire installation process.

17.11.6 At T-shaped seams the additional nonwoven strip may not be layed between Bentofix® rolls.

17.12 If the specification does ask for taping of overlaps, the overlap widths can be reduced to 150mm on panel edges and 300mm on panel ends. In this case section 17.13 to 17.27 is applicable.

17.13 To ensure best sealing performance of the approved tape the weather conditions should be dry and the temperature should be in the range of 4°C to 40°C.

17.14 The coated surface of Bentofix® NSP X-type GCLs should be dry, clean and free from dust, grease or any other influencing particles. Water, other fluids or dust will affect the sticking and sealing effect of the approved tape.

17.15 Prior to attaching the tape to the coating of Bentofix® NSP X-type GCLs it may be recommended to wipe and clean and dry the coating area to which the tape should

be attached with a clean cloth and a fluid solution of water and isopropyl alcohol.

17.16 Once the weather conditions meet the requirements of section 17.13 and the coating surface conditions meet the requirements of section 17.14 and 17.15, the tape can be attached to the coated GCL overlap.

17.17 It is important to apply the tape shortly after removing the release foil (fig. 17) and ensuring that it is placed directly on the coating of the GCL with light pressure and without any air traps, moisture, dust or other particles being captured between coating and tape.

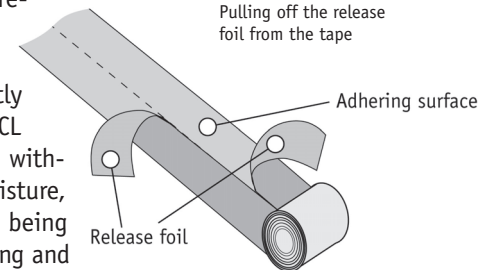

Fig. 17
Pulling off the release foil from the tape

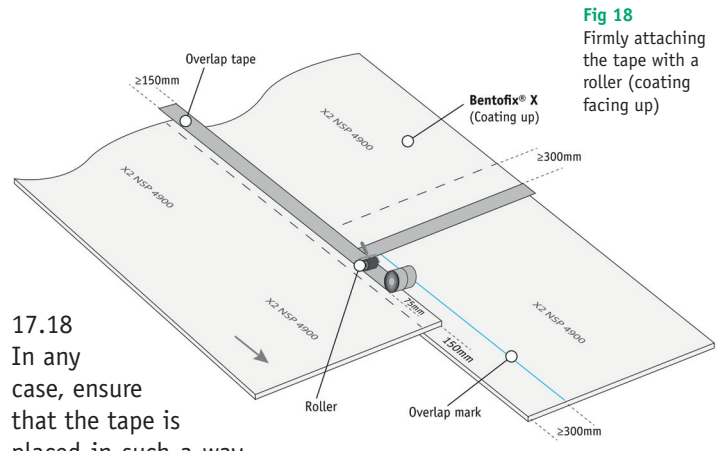

Fig. 18
Firmly attaching the tape with a roller (coating facing up)

17.18 In any case, ensure that the tape is placed in such a way that the edge overlap is covered with 75mm on both sides (fig. 18).

17.19 Use a roller to then place the tape firmly to the coated GCL (fig. 18).

17.20 Once the tape attachment process is finished or has to be interrupted, simply use a cutter knife or suitable scissor (best with titane anti adherent surface) to cut the tape (fig. 19). If the taping is continued, simply overlap the already placed tape 150mm and ensure the same surface conditions as described.

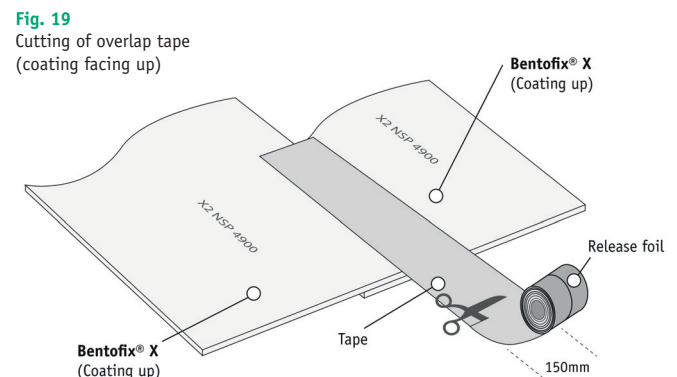

Fig. 19
Cutting of overlap tape (coating facing up)

17.21 If the coating is facing down, special care is needed such that the surfaces of the coating and the overlap tape remain, as described in section 17.14, dry and clean at any time. Further it is required to follow section 17.13 to 17.18 and 17.22 to 17.29.

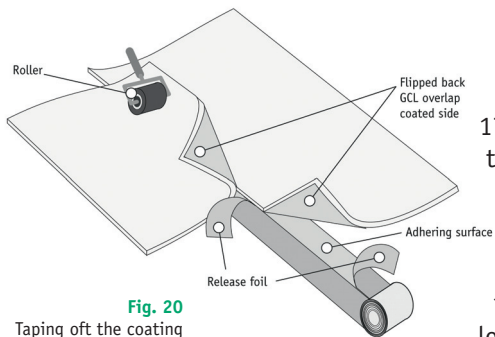

Fig. 20
Taping off the coating surface facing down

17.22 Bentofix® NSP X-type GCL overlaps that require a taping need to be turned back (fig. 20).

17.23 Ensure that the lower Bentofix® GCL is taped first, ensuring a dry and clean surface as described in section 17.14.

17.24 It is important to apply the tape shortly after removing only one side of the release foil and ensuring that it is placed directly on the coating of the GCL with light pressure and without any air traps, moisture, dust or other particles being captured between coating and tape.

17.25 Turn down the taped Bentofix® GCL.

17.26 Ensure that the surface of the overlapping coated side of the upper Bentofix® NSP X-type, as well as the remaining overlap tape with the release foil, fulfill the same surface requirements as described in section 17.14 and 17.15.

17.27 Only then remove the second half of the release foil of the tape and slowly lower the overlapping Bentofix® X-type GCL ensuring the butyl tape stays free from moisture or dust.

17.28 Use a roller to then ensure a good bonding between overlap tape and coating (fig. 20).

17.29 The tape cutting is described in section 17.20.

18. Attachment Details

18.1 Bentofix® GCL should be installed around penetrations, pipes, and other structures according to the contract drawings and guidelines. Sealing of these areas are main priority.

18.2 Bentofix® may be secured to the structures by use of a stainless steel batten or clamp, mechanical fasteners, or other appropriate device if necessary for minimizing movement. A typical Bentofix® attachment to a concrete structure is shown in the figure 21.

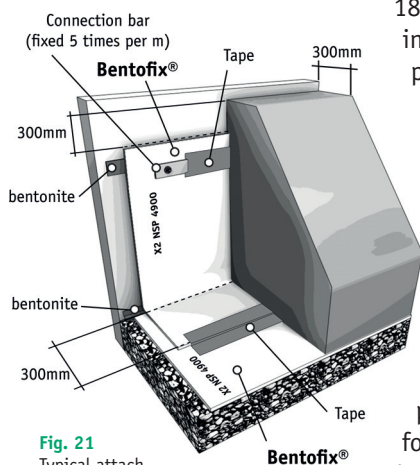

Fig. 21
Typical attachment detail

18.3 Typical Bentofix® attachment to vertical and horizontal pipe penetrations is shown in figure 22.

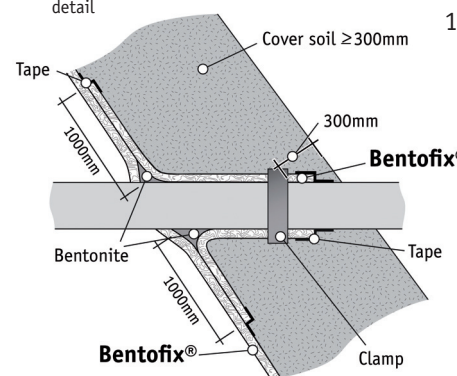

Fig. 22
Typical penetration detail

18.4 Cutting the GCL should be accomplished using a sharp utility knife. Frequent blade changes are recommended to avoid damage to the synthetic components of the GCL during the cutting process.

18.5 Additional bentonite or bentonite paste is necessary to maximize the seal.

18.6 If a taping is required for connections or penetrations, then section 17 is to be followed. In these cases half of the tape must be connected to the coating of Bentofix® as well as to the connection or penetration.

18.7 Contact the manufacturer regarding attachments to structures or details.

19. Cover Placement

19.1 In all cases it is required that the responsible designer approves the slope stability analysis of the system.

19.2 Cover soils shall be free of sharp-edged stones or other foreign matter that could damage the GCL. Cover soils should be an approved material with respect to particle size uniformity, moisture content, and chemical compatibility. Recommended cover soils typically have a well-graded particle size distribution ranging between fines and 25mm. Soils with greater than 50% of material (by weight) larger than 20mm may require a field-scale test using the proposed subgrade surface, cover soil, and placement and compaction equipment.

19.3 Placement of sandy soils over Bentofix® should be preferred.

19.4 Soils can be placed on top of Bentofix® if the bentonite moisture content is less than 50%.

19.5 Soil cover shall be placed over the GCL using construction equipment that minimizes stresses on Bentofix®.

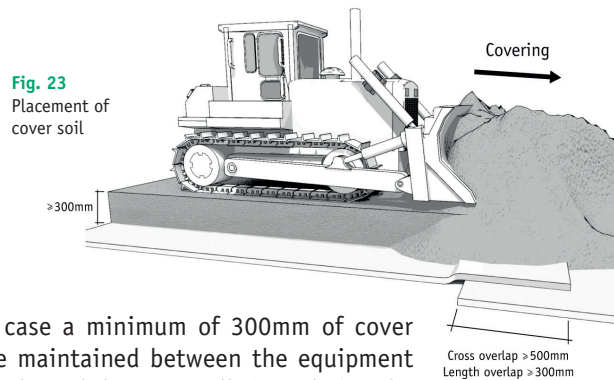

Fig. 23
Placement of cover soil

In any case a minimum of 300mm of cover shall be maintained between the equipment tires/tracks and the GCL at all times during the covering process (fig. 23).

19.6 Frequent traffic can be run over a soil coverage of at least 800mm. Differing thickness or soil material might be possible due to site conditions and soils. In this case please contact NAUE or their local representative.

19.7 Soil cover should be placed on Bentofix® by carefully pushing the soil on top of the GCL (figure 23), without causing any damage and in a manner that prevents the soil from entering the GCL overlap zones.

19.8 To prevent overlaps being separated during soil placement, it is possible to manually place soil on top of the overlaps.

19.9 When another geosynthetic material is placed over the GCL, care must be taken to avoid using equipment and construction practices that could damage the GCL.

19.10 Typically the 300mm cover soil placement should also be placed directly on top of the geosynthetic material (see 19.9), prior to any bentonite hydration over 50% moisture content.

19.11 After placement of the minimum 300mm thick cover soil layer, the final cover soil thickness should be placed in less than two weeks.

20. Interruptions during Installation

20.1 Uncovered areas should be protected at the edges overnight with a plastic membrane (fig. 10) to prevent bentonite hydration.

20.2 In the event of rainfall, which could cause a pre-hydration of the bentonite portion of the unconfined GCL of more than 50%, a temporary cover consisting of a water-proof tarpaulin or plastic sheet to protect the GCL should be placed over the GCL.

20.3 The edges of exposed sheets should be weighted down with sandbags or equivalent ballast, which does not cause any damage to the GCL, to prevent uplift in the event of strong winds.

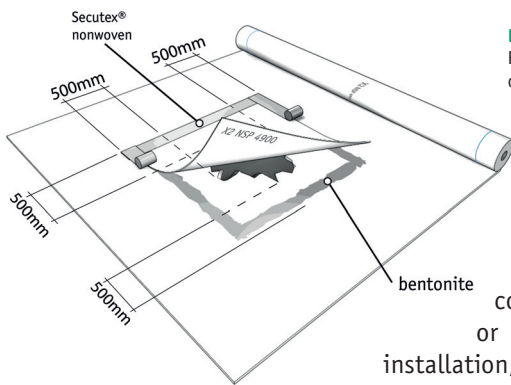

Fig. 24
Repairing of
damaged sections

21. Repairs

21.1 In the event that an area of Bentofix® GCL becomes damaged, torn or punctured during installation, the affected area should be repaired (fig 24).

21.2 On relatively level surfaces, the damaged area should be covered with a separate piece of Bentofix® GCL extending at least 500mm beyond the damaged area in every direction.

21.3 All overlaps shall be treated as described in section 17.

21.4 Damaged GCL material on slopes shall be repaired by the same procedures as described in section 21.2 and 21.3,

21.5 Care must be taken during the placement of cover materials to ensure that the patch is not displaced.

21.6 Areas that are exposed to standing water or excess precipitation with resulting excessive bentonite hydration ($\geq 50\%$) prior to soil covering should be examined for damage by subsequent activities.

If it is determined that the GCL has been hydrated and damaged, the GCL should be covered with a new GCL piece over the affected area or removed and replaced.

21.7 All Bentofix® GCLs where bentonite was exposed to hydrocarbon fuels, chemicals, non-compatible liquids, or other harmful liquids during the installation should be removed and replaced with non-affected Bentofix® GCL.

22. Inspection

22.1 After deployment and seaming, a close visual inspection of the Bentofix® GCL rolls and seams shall be made by the project engineer or an approved person. This is done as soon as possible after deployment has been completed.

22.2 The inspection shall include overlaps, alignments, penetrations, connections, detection of defects, including installation damage. Detected falsely installed areas shall be marked, repaired and the repairs shall be inspected and approved by the project engineer or an approved person.

22.3 This inspection/repair process is to be carried out in a systematic manner as soon as possible to ensure that no defective area stays unrepaired.

22.4 Once the inspection has passed the next layer of geosynthetics may be installed or the spreading of the cover soil can begin in a method not harmful to the installed GCL.

23. Hydration of Bentonite

23.1 In cases where the containment of non-aqueous liquids is required, it may be necessary to hydrate the covered GCL with water prior to use.

23.2 If necessary prehydration may be accomplished (provided that the clay component of the GCL is covered by permeable materials) by introducing water into the containment area, either by flooding or by the use of sprinklers. NAUE GmbH & Co. KG or their local representative should be contacted for specific procedures if manual hydration is necessary.

23.3 Traffic running over hydrated areas should not damage the GCL by bentonite squeezing. Higher cover soil thicknesses are recommended.

24. Special Conditions

For other specific procedures contact a NAUE representative.

Installation Briefing

 practical theoretical

1. Name of site: _____

2. Date: _____ Time from: _____ to: _____

3. Product-type: _____

Visual inspection of geosynthetic: _____

4. Contractor: Company: _____

Name: _____

Tel.: _____ Fax.: _____

Email: _____

5. Installer: Company: _____

Name: _____

Tel.: _____ Fax.: _____

Email: _____

6. Weather:

Temperature: _____ sunny cloudy Rain/Snow light
 medium
 strong

7. Installation guideline available on construction site: yes no

Status of guideline: _____

8. Subbase condition: _____

9. Contractor/installer informed on placement of cover material:

Type of cover/geosynthetic material min. thickness of cover Direction of placement

Direction of spreading Overlapping Geosynthetic storage area

10. Photo documentation: yes no GPS position _____

Photos filed: yes no File location _____ Marked in installation plan: yes no

11. Notes on additional pages: yes no _____

12. Confirmation of briefing:

Name: _____ Name: _____

Company: _____ Company: _____

Date, signed: _____ Date, signed: _____



NAUE GmbH & Co. KG
 Gewerbestrasse 2
 32339 Espelkamp-Fiestel
 Germany

Phone +49 5743 41-0
 Fax +49 5743 41-240
 E-Mail info@naue.com
 Internet www.naue.com



is a registered trademark of NAUE GmbH & Co. KG in various countries.

The information contained herein is the best to our knowledge, true and accurate. There is no implied or expressed warranty.

© 2013 by NAUE GmbH & Co. KG, Espelkamp-Fiestel, Germany · All rights reserved. · No. F 3 · Status 08.08.2013

Bentofix® unloading

Status and No. of installation guideline

Date	Roll Nr.	Weather	Damages		Fixed		Comments	Name symbol
			<input type="checkbox"/> YES	<input type="checkbox"/> NO	<input type="checkbox"/> YES	<input type="checkbox"/> NO		
			<input type="checkbox"/> YES	<input type="checkbox"/> NO	<input type="checkbox"/> YES	<input type="checkbox"/> NO		
			<input type="checkbox"/> YES	<input type="checkbox"/> NO	<input type="checkbox"/> YES	<input type="checkbox"/> NO		
			<input type="checkbox"/> YES	<input type="checkbox"/> NO	<input type="checkbox"/> YES	<input type="checkbox"/> NO		
			<input type="checkbox"/> YES	<input type="checkbox"/> NO	<input type="checkbox"/> YES	<input type="checkbox"/> NO		
			<input type="checkbox"/> YES	<input type="checkbox"/> NO	<input type="checkbox"/> YES	<input type="checkbox"/> NO		
			<input type="checkbox"/> YES	<input type="checkbox"/> NO	<input type="checkbox"/> YES	<input type="checkbox"/> NO		
			<input type="checkbox"/> YES	<input type="checkbox"/> NO	<input type="checkbox"/> YES	<input type="checkbox"/> NO		
			<input type="checkbox"/> YES	<input type="checkbox"/> NO	<input type="checkbox"/> YES	<input type="checkbox"/> NO		
			<input type="checkbox"/> YES	<input type="checkbox"/> NO	<input type="checkbox"/> YES	<input type="checkbox"/> NO		
			<input type="checkbox"/> YES	<input type="checkbox"/> NO	<input type="checkbox"/> YES	<input type="checkbox"/> NO		
			<input type="checkbox"/> YES	<input type="checkbox"/> NO	<input type="checkbox"/> YES	<input type="checkbox"/> NO		
			<input type="checkbox"/> YES	<input type="checkbox"/> NO	<input type="checkbox"/> YES	<input type="checkbox"/> NO		
			<input type="checkbox"/> YES	<input type="checkbox"/> NO	<input type="checkbox"/> YES	<input type="checkbox"/> NO		
			<input type="checkbox"/> YES	<input type="checkbox"/> NO	<input type="checkbox"/> YES	<input type="checkbox"/> NO		
			<input type="checkbox"/> YES	<input type="checkbox"/> NO	<input type="checkbox"/> YES	<input type="checkbox"/> NO		
			<input type="checkbox"/> YES	<input type="checkbox"/> NO	<input type="checkbox"/> YES	<input type="checkbox"/> NO		
			<input type="checkbox"/> YES	<input type="checkbox"/> NO	<input type="checkbox"/> YES	<input type="checkbox"/> NO		
			<input type="checkbox"/> YES	<input type="checkbox"/> NO	<input type="checkbox"/> YES	<input type="checkbox"/> NO		

Onsite storage according to chapter 9 of Bentofix® installation guidelines YES NO

Comments

Name symbol

Name symbol	Name	Company





NAUE GmbH & Co. KG
Gewerbestr. 2
32339 Espelkamp-Fiestel
Germany

Phone +49 5743 41-0
Fax +49 5743 41-240
E-Mail info@naue.com
Internet www.naue.com



and Bentofix® are registered trademarks of NAUE GmbH & Co. KG in various countries.

The information contained herein is the best to our knowledge, true and accurate. There is no implied or expressed warranty.
© 2013 by NAUE GmbH & Co. KG, Espelkamp-Fiestel, Germany · All rights reserved. · V34 · Status 08.08.2013