

Contents	Page
1. Scope	1
2. Quality Statement	2
3. Packaging	2
4. Labelling	2
5. Roll Imprint	2
6. Plant Storage	2
7. Transportation to Site	2
8. Unloading Procedures	2
9. Storage on Site	3
10. Recommended Equipment	3
11. Qualification for Installer	3
12. Weather Conditions for Installation	3
13. Subgrade Preparation	3
14. Slopes	4
15. Anchoring	4
16. Installation of Bentofix®	4
17. Overlaps and Seaming	5
18. Attachment Details	6
19. Cover Placement	7
20. Interruptions during Installation	7
21. Repairs	7
22. Inspection	7
23. Hydration of Bentonite	8
24. Special Conditions	8

lation guidelines, taking into account all aspects of the application. NAUE GmbH & Co. KG assumes no liability for the incorrect use of the product in an application. Any liability for errors in these installation guidelines is also excluded.

For further information or questions, please contact the planner, designer or NAUE GmbH & Co. KG.

1. Scope

1.1 Bentofix® geosynthetic clay liners (GCLs) are needle-punched, reinforced composites that combine two durable geotextile outer layers and a uniform core of high-swelling sodium bentonite powder. This construction forms a shear resistant hydraulic barrier with self-sealing characteristics.

1.2 During the manufacturing process the cover of Bentofix® NSP types is impregnated during the production with bentonite powder at the edges on both sides in length direction in a width of 500mm (logitudinal overlaps) (Fig. 1 and Fig. 1a). This bentonite impregnation allows a simple self-sealing overlap at the edges in length direction, without any supplemental bentonite placement on site.

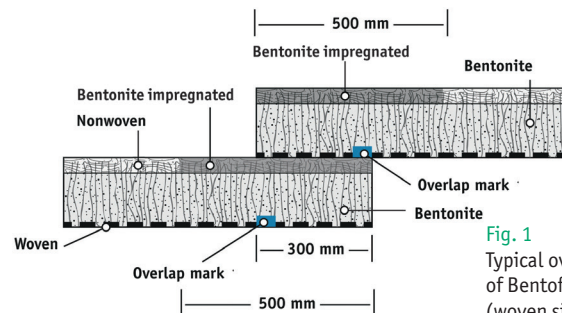

Fig. 1
Typical overlap of Bentofix® NSP types (woven side down)

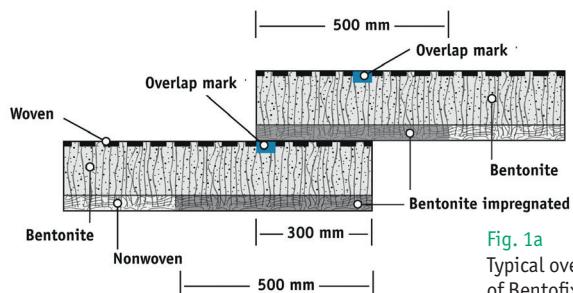

Fig. 1a
Typical overlap of Bentofix® NSP types (woven side up)

These installation instructions contain only general recommendations and do not replace the detailed design. The requirements of a tender or a specific project may give rise to significant deviations which, in the event of a conflict, will take precedence over these instructions. These guidelines do not cover all possible safety issues in connection with the use of the product.

It is the responsibility of the user to take appropriate safety and health measures and to determine and fulfil possible legal or official regulations and requirements.

Furthermore, these installation guidelines do not cover all possible climatic, chemical, physical, hydraulic or geometric boundary conditions on the construction site.

The information contained in these installation guidelines corresponds to the latest state of knowledge of NAUE GmbH & Co. KG at the time this document was prepared. We reserve the right to revise it. Please inform yourself about the relevant technical state of knowledge at the time of installation.

It is the responsibility of the customer to check the correctness and completeness of the information contained in these instal-

1.3 The subbase, the Bentofix® GCL as well as the minimum 300mm thick cover soil make the sealing system. Bentofix® GCLs are a sealing element and are not designed to absorb tensile strengths.

1.4 Bentofix® is produced following strict ISO 9001 quality control procedures. Good practice may influence the performance of the geosynthetic in a properly designed application.

1.5 This installation guideline is applicable for all Bentofix® NSP types without any additional coating barrier.

1.6 This Bentofix® installation guideline is not applicable for underwater installation applications.

1.7 This guideline must be present to the installer and the responsible site engineer.

2. Quality Statement

2.1 NAUE GmbH & Co. KG as the inventor of needle-punched GCLs in 1987 is dedicated to continuous quality. This commitment begins with the manufacture of the Bentofix® Geosynthetic Clay Liner (GCL) material and its components (as well as the quality control of these and their components), and continues until our customer has accepted the GCL.

2.2 NAUE GmbH & Co. KG is fully ISO 9001 (2015) registered.

3. Packaging

3.1 Manufactured Bentofix® rolls are usually rolled on cores that have a crushing strength sufficient to avoid collapse or other damage in normal use.

3.2 Bentofix® rolls are wrapped with a protection sheet to avoid effects to the roll due to shipment, water, sunlight or contaminants while being stored, transported or handled.

3.3 In the unlikely case of a damage to the wrapping, the damaged area is either fixed with tape (Fig. 2) or is fully replaced.

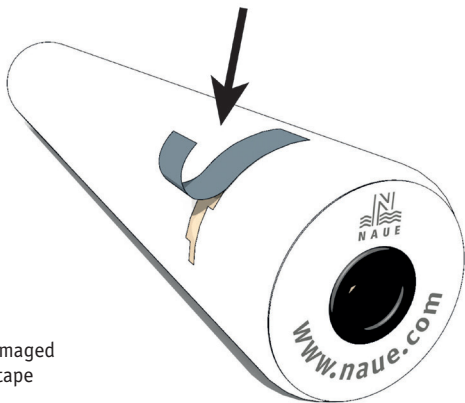

Fig. 2 Bonding the damaged packing with a tape

4. Labelling

On the wrapping of each roll a label with handling guidelines and an identification label (Fig. 3) are fixed which include:

- Name of manufacturer
- Product identification
- Roll dimension
- Unique roll number
- Total mass per unit area



Fig. 3 Typical Bentofix® roll label

5. Roll Imprint

Each roll of Bentofix® NSP type geosynthetic clay liner is printed on the slit-film woven side with the product name and type name as well as with a continuous overlap line on each side of the woven, 300mm from the edge. The product imprint and the overlap lines after unrolling are, if not otherwise requested, faced down against the subgrade (Fig. 4).

6. Plant Storage

6.1 Bentofix® rolls are transported in the manufacturing facility by means of stinger bars and are stored so that no damage affects the performance of the material or of the wrapping.

6.2 Bentofix® rolls are stored covered on elevated, dry and smooth ground, which will prevent any damage to the wrapping of the rolls.

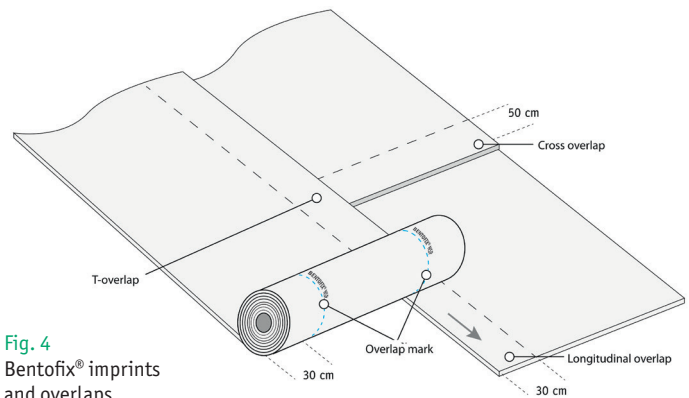

Fig. 4 Bentofix® imprints and overlaps

7. Transportation to Site

7.1 Bentofix® GCL rolls are delivered to the working area of the site in their original packaging on trucks or in containers. The storage surface should be elevated, dry and smooth, to prevent any damage to the wrapping of the rolls.

7.2 In general no supplementary bentonite powder is needed for Bentofix® NSP type overlaps in length direction. Exceptions that require additional bentonite powder may be where there is a requirement for penetrations, cross overlaps or speciality connection details of the Bentofix® GCL. In this case bentonite powder in bags as well as approximately 200mm wide nonwoven strips are required. The necessary amount needed must be ordered prior to shipment. These are typically transported such that they do not get wet.

7.3 Before Bentofix® rolls are unloaded it is recommended to identify and verify the shipment and check whether any rolls are damaged. In the unlikely case of damage, details should be noted and reported to the forwarding company and the supplier.

8. Unloading Procedures

8.1 As with any lifting or loading operations, appropriate safety equipment should be employed and proper safe handling methods practised. This includes an appropriate and firm subbase for the vehicle and the Bentofix® storage. The party responsible for unloading the Bentofix® GCL should contact the manufacturer prior to shipment to determine the correct unloading methods and equipment if different from the pre-approved and specified methods. Use Appendix B to make notes if necessary.

8.2 The storage area for Bentofix® rolls must follow section 9.

8.3 For unloading of vehicles, the following methods are suitable. GCL type dependent 5m wide Bentofix® GCL rolls can weigh in general between 900 and 1,200kg.

- Slings: two slings ($\geq 70\text{mm}$ width) with sufficient strength (approx. 1/3rd of the roll width away from the edge), which are fixed to the lifting device, with which (depending on the strength of the slings) one or more rolls can be moved without damaging the GCL or the packaging.
- Spreader Bar Assembly: Lifting the rolls can be accomplished with a steel pipe/bar (preferably solid), with a wall thickness capable of providing sufficient beam strength to support the weight of the roll without bending. The core pipe is inserted through the centre PVC core pipe (ca. 125mm diameter) of the Bentofix® roll. Heavy-duty slings or chains are attached to each end of the pipe, which are then fastened to a spreader bar and cannot damage the GCL roll (Fig. 5) and prevent chains or straps from chafing the roll edges.

The GCL wrapping should only be removed shortly before the rolls are installed. Bentofix® rolls should be transported to the construction site using a spreader bar (Fig. 5) or lying on a suitable construction site vehicle. A crane, backhoe, frontend loader or any other suitable piece of equipment can lift the entire assembly.

8.4 In the unlikely case of damage to the wrapping, the damaged area is either fixed with tape (fig. 2) or is fully replaced.

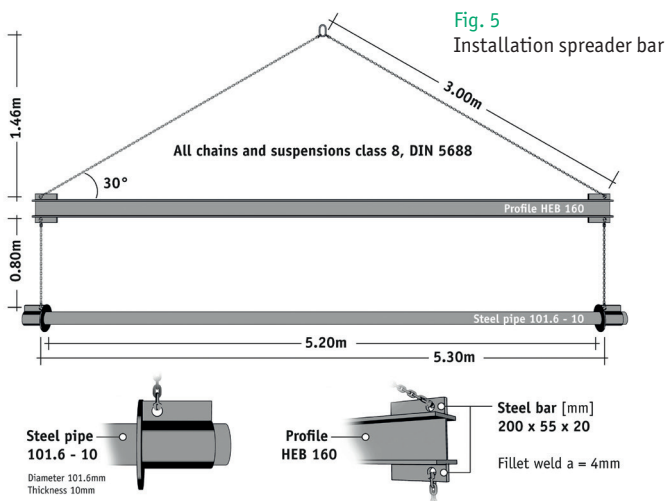

9. Storage on Site

9.1 A storage area is required that is flat, dry, and well drained to keep the Bentofix® GCL dry and large enough to store the delivered amount of GCL rolls. The surface should be free of sharp rocks or other objects that could damage the GCL. The storage area must be as close as practicable to the work area to minimize on site handling.

9.2 The storage area must be secure to prevent vandalism, theft, and must be such that rolls are unlikely to be damaged by passing vehicles. Rolls of Bentofix® and bentonite for the overlap areas need to be covered with a plastic sheet or tarpaulin until their installation.

9.3 Any rolls that come in contact with moisture while in storage should be examined prior to installation to ensure that subsequent physical damage has not occurred. Physically damaged rolls should be set aside for further examination to determine the plausibility of repair.

9.4 Bentofix® GCLs can be stacked up to five rolls high if stored on site (Fig. 6). It must be ensured that rolls cannot move at any time once stacked and stored. If rolls need to be stacked higher please contact NAUE or their representative.

9.5 Arrange storage so that access can be maintained to one or preferably two sides of the stored GCL rolls. Pulling of rolls should be avoided.

9.6 On site delivered bags with bentonite and nonwoven strips should also be stored dry and if necessary protected with a waterproof and resistant plastic sheet.

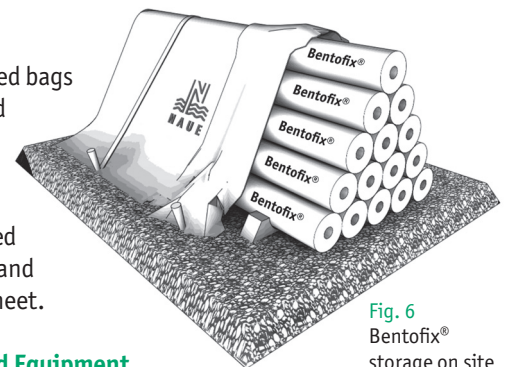

Fig. 6 Bentofix® storage on site

10. Recommended Equipment

- Approved vehicles, e.g. excavator
- Excavator
- Spreader bar
- Utility knife
- Trowel
- Bucket
- Shovel
- Marker
- Yardstick

11. Qualification for Installer

11.1 The installation crew must have knowledge of the Bentofix® installation guidelines and be trained on the installation procedure of Bentofix® GCLs.

11.2 It is recommended to note the date of training in the construction journal. Appendix A can be used as a general format.

11.3 NAUE or their local representative personnel staff can train installers if requested. Details are to be determined prior to the training.

12. Weather Conditions for Installation

12.1 The weather conditions should allow a dry installation of Bentofix® GCLs and the placement of the cover materials.

12.2 The subbase must fulfill the specification or requirements as stated in section 13.

12.3 It must be possible to install the rolls in accordance with sections 13 to 19. Installed rolls with a moisture content of ≤ 50 (determination of water content according to DIN 18121) can be filled with soil, provided the information in section 19 is observed.

13. Subgrade Preparation

13.1 The surface upon which the Bentofix® GCL is installed should be smooth and free of debris, roots, sticks and sharp rocks/boulders larger than 50mm. Site specific compaction requirements should be followed in accordance with the project plans and specifications.

13.2 At a minimum, the level of compaction should be such that installation equipment or other construction vehicles that traffic the area of deployment do not cause significant rutting.

13.3 In applications where the Bentofix® GCL will be subjected to a hydraulic head that exceeds the cover soil confining stress, subgrade surfaces consisting of gravel or granular soils may not be acceptable due to their large void content. For these applications, the top 150mm of the subgrade soil should possess a particle size distribution where at least 80 percent of the soil is finer than 0.63mm with a maximum particle size of 12mm. Directly prior to deployment of the Bentofix® GCL, the subgrade shall be final-graded to fill in any remaining voids or desiccation cracks and proof-rolled to ensure that no sharp irregularities or abrupt elevation changes exist greater than 25mm.

13.4 The surfaces to be lined shall be maintained in this condition, free of standing water.

13.5 If required the subgrade preparation and surface should be inspected and certified by a CQA inspector prior to Bentofix® GCL placement. Upon approval by the CQA inspector, it should be the installer's responsibility to indicate to the engineer any change in the condition of the subgrade that could cause it to be out of compliance with any of the requirements of the project specific specification.

14. Slopes

14.1 In all cases it is required that the responsible designer approves the slope stability analysis of the system.

14.2 On slopes with an inclination larger than 17% (9.65°; 1V:6H) and 3m length it is necessary to install Bentofix® in direction of the slope. In any cases the relative friction angles should be confirmed with shear box tests. Cross-overlaps are to be avoided. Should this not be possible, then cross-overlaps have to be in the direction of the water flow (Fig. 7; roof tile system).

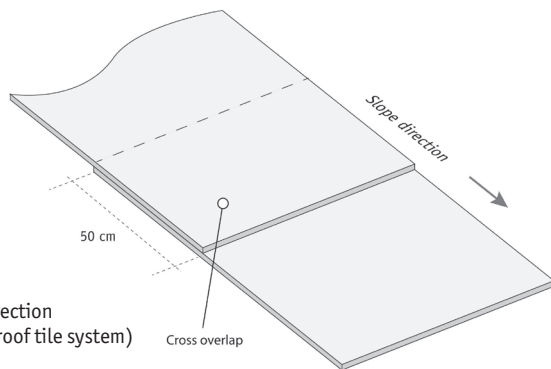

Fig. 7
Overlaps in direction of waterflow (roof tile system)

14.3 If slopes exceed an inclination of 28.6% (16°; 1V:3.5H) hidden anchor trenches in the slope might be applicable and should be approved by the responsible designer.

14.4 If anchor trenches are specified at the top of the slopes, then follow section 15.

15. Anchoring

15.1 Bentofix® GCL is typically anchored in a trench on the top of slopes, e.g. around the perimeter of the containment basin to provide the required pullout resistance. In most cases Bentofix® GCLs can be anchored in the same trench as any adjacent geosynthetic liner components (if used).

15.2 Dimensions and location of the trench should be provided in the project drawings or from figure 8. Alternatively the material may be anchored by deploying additional run-out of material past the slope crest.

15.3 The front edge of the trench should be rounded to eliminate any sharp corners that could cause excessive stress on the GCL.

15.4 When an anchor trench is required, it shall be excavated no more than two days ahead of GCL placement. This should prevent the trench sides from falling in and requiring re-excavation.

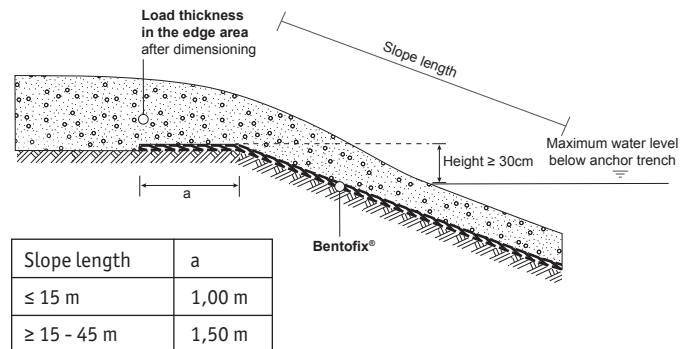

Fig. 8 a
Minimum dimensions for structural integration at the crest of the slope

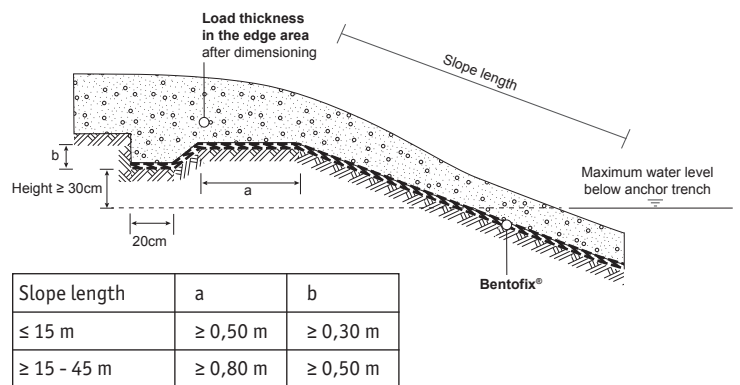

Fig. 8 b
Minimum dimensions for structural integration at the crest of the slope

15.5 When the panels are placed in position, the anchor trench must be loosely backfilled or loaded with sandbags immediately.

15.6 The appropriate backfill procedures should be in accordance with the project drawings and specifications.

15.7 The lowest point of any anchorage should be minimum 300mm higher than the highest water table, e.g. in a containment application.

15.8 Other anchor trench systems are possible, if approved in coordination with the manufacturer, supplier or designer.

16. Installation of Bentofix®

16.1 GCL rolls are to be delivered to the working area of the site in their original packaging.

16.2 As Bentofix® rolls are selected for deployment, the roll labels should be removed and recorded by the installer or the quality control inspector along with any other pertinent information. Only approved material may be installed (Appendix C can be used to make notes).

16.3 Immediately prior to deployment, the packaging shall be carefully removed without damaging the GCL. Overlap marks on both sides indicate the bottom side which is placed on the subgrade.

16.4 The layout and sequence of panel placement is determined by direction of water run-off. Panels are laid out according to the previously approved panel layout drawings, when such drawings are available.

16.5 Generally, the installation is started at the top of the slope and at the highest elevation so that any rainfall runs off the lower part of the impoundment, this prevents water from hydrating the GCL.

16.6 When in position, panels are checked for any physical damage.

16.7 All Bentofix® GCL rolls should be installed in a relaxed condition, and be free of wrinkles and folds.

16.8 Rolls of Bentofix® material are unrolled using a frontend loader or other approved handling equipment. A spreader bar (Fig. 5) or other approved apparatus is attached to the bucket or the front of the equipment.

16.9 Panels on slopes are placed so that the seam runs parallel to the direction of the slope. Flat areas are laid in no particular orientation, but the panels should be shingled in the down-slope direction to facilitate drainage.

16.10 If required, a smooth piece of geomembrane will be used as a rub sheet to facilitate deployment of other geosynthetic layers. The rub sheet does not need to run the entire length of the slope, only the top crest and first few metres of the slope need to be covered to facilitate deployment. After use, the rub sheet has to be removed.

16.11 No equipment that could damage the GCL shall be allowed to travel directly on the GCL. Acceptable installation, for example, may be accomplished such that the GCL is unrolled in front of the backwards-moving deployment equipment, such as a frontend loader or bulldozer. If the equipment causes rutting of the subgrade, the subgrade must be restored to its originally accepted condition before placement continues.

16.12 Only as much Bentofix® GCL as can be covered by the end of the day should be deployed, or such amount that can be covered in a reasonably short time in the event of precipitation. Uncovered overlap edges should be protected overnight with a plastic membrane (Fig. 9) to prevent bentonite hydration. The edges of exposed sheets should be weighted down with sandbags or equivalent ballast, which does not cause any damage to the GCL, to prevent uplift in the event of strong winds.

16.13 Cutting of Bentofix® GCLs may be required at some times, e.g. around penetrations. This can be accomplished by using a sharp utility knife. Frequent blade changes are recommended to avoid damage to the geosynthetic components of the GCL during the cutting process. Removed blades should not be discarded on or under installed Bentofix®.

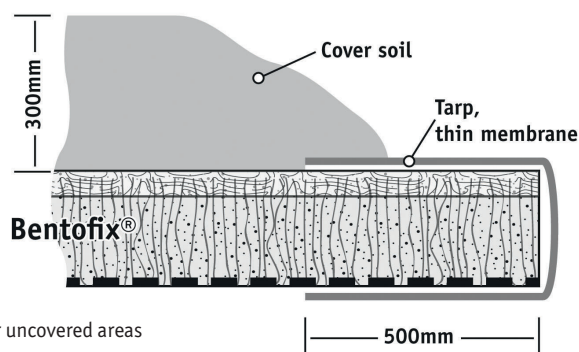

Fig. 9
Details for uncovered areas

17. Overlaps and Seaming

17.1 GCL seams are constructed by overlapping their adjacent edges. Care should be taken to ensure that the overlap zone is not contaminated with loose soil or other debris.

17.2 Do not walk on or drive over overlap areas.

17.3 Do not lay identical Bentofix® surfaces over each other (e.g. slit-film woven on top of slit-film woven).

17.4 Seams should be constructed such that they are shingled in the direction of the grade in a manner that prevents the potential for flow entering the overlap zone.

17.5 T-shaped seams (Fig. 10) should be reduced to a minimum.

17.6 Two adjacent laying end overlaps (cross overlaps) are not allowed.

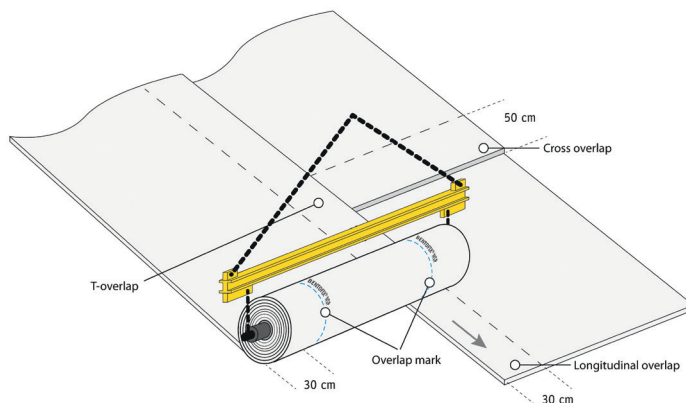

Fig. 10
Unrolling and overlapping of Bentofix®

17.7 Overlaps in low points should be avoided.

17.8 Unless otherwise specified, the minimum dimension of the longitudinal overlap should be 300mm. The edge overlap lines of Bentofix® allow the line-up during the unrolling process (Fig. 10). End-of-roll overlapped seams should be constructed similarly but the minimum overlap should measure 500mm. Care should be taken to maintain these overlap dimensions at the time of covering, in all climatic conditions.

17.9 To prevent uplift in the event of strong winds it may be necessary to place sand bags or approved soil material over overlap areas.

17.10 Rolls should be adjusted to smooth out wrinkles or creases between adjacent panels while leaving the proper overlap and be free of wrinkles, folds or "fish-mouths" when covered.

17.11 Overlaps in length direction (longitudinal overlaps): It is necessary that the woven side of Bentofix® NSP types are overlapped with a minimum of 300mm onto the bentonite impregnated area of the nonwoven side. If this is not possible, the overlaps shall be treated according to section 17.12.

17.12 Cross overlaps: Cross overlaps of Bentofix® NSP types are not impregnated during manufacturing with additional bentonite. It is therefore necessary that cross overlaps are sealed on site with supplemental bentonite powder (section 17.12.1) or bentonite paste (17.12.2).

17.12.1 Bentonite powder:

These overlapping edges are pulled back and bentonite similar to that used in the product should be poured in a suitable manner 200mm wide continuously along all seam edges, typically 0.6kg/m (Fig. 11).

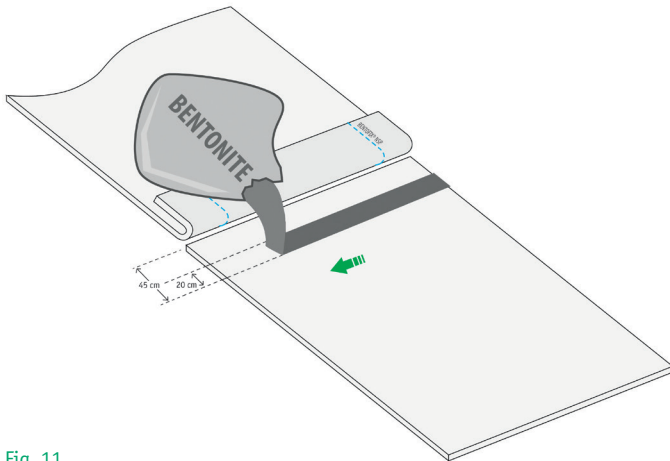

Fig. 11
Placing of bentonite onto the overlap

17.12.2 Bentonite paste:

While constantly mixing, bentonite should be added to water (approx. 4 - 6 times the amount of bentonite) in a sufficient large bucket. Typically an electrical mixer with an attached mixing paddle is recommended.

The bentonite paste is then spread approx. 200mm wide and 10mm thick into the overlap zone and pressed into the nonwoven component of the GCL with a trowel, shovel or similar device (Fig. 12).

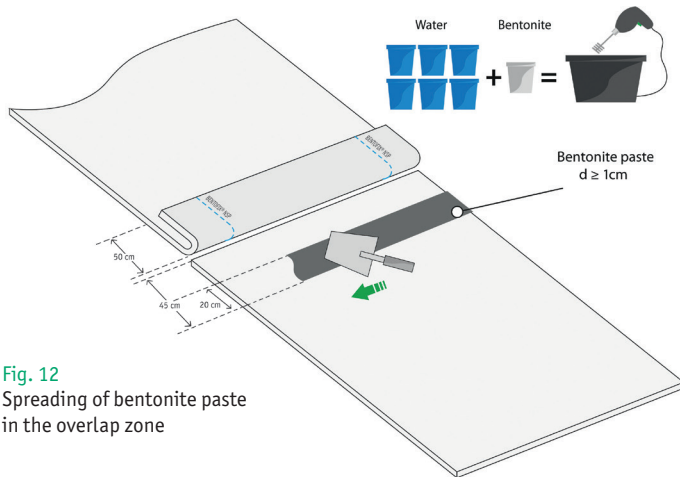

Fig. 12
Spreading of bentonite paste in the overlap zone

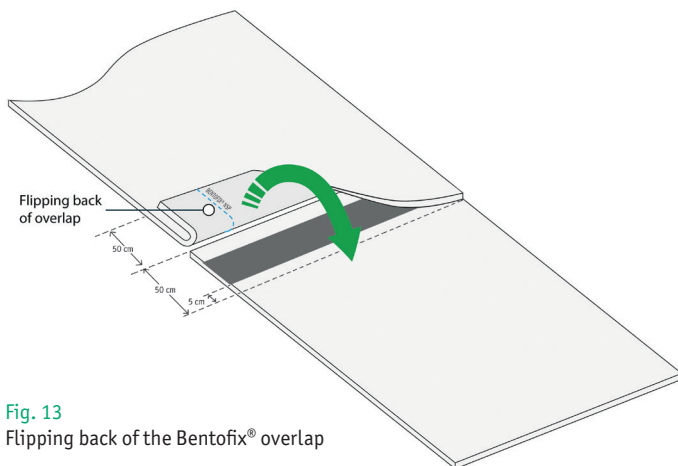

Fig. 13
Flipping back of the Bentofix® overlap

17.12.3 After placing the bentonite powder or paste in the overlap zone, it is necessary to overlap the area with the neighbouring Bentofix® roll (e.g. Fig. 13). If using bentonite paste this should occur shortly after placing the bentonite paste to avoid a drying of the wet bentonite.

18. Attachment Details

18.1 Bentofix® GCL should be installed around penetrations, pipes, and other structures according to the contract drawings and guidelines. Sealing of these areas are main priority.

18.2 Bentofix® may be secured to the structures by use of a stainless steel batten or clamp, mechanical fasteners, or other appropriate device if necessary for minimizing movement. A typical Bentofix® attachment to a concrete structure is shown in the figure 14.

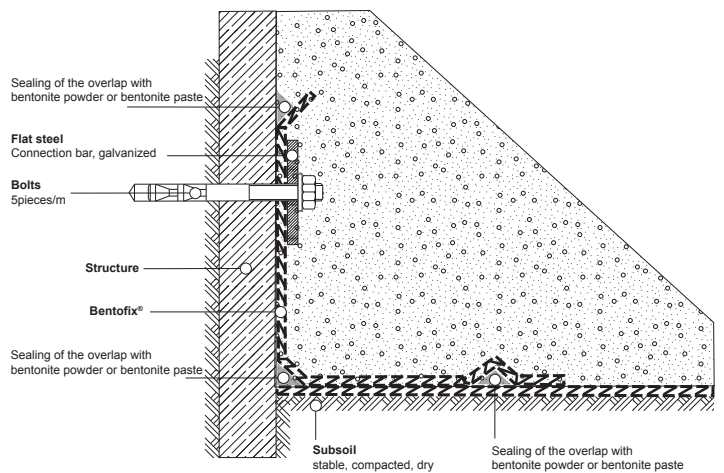

Fig. 14
Typical attachment detail

18.3 Typical Bentofix® attachment to vertical and horizontal pipe penetrations is shown in figure 15.

18.4 Cutting the GCL should be accomplished using a sharp utility knife. Frequent blade changes are recommended to avoid damage to the synthetic components of the GCL during the cutting process.

18.5 Additional bentonite or bentonite paste is necessary to maximize the seal.

18.6 Contact the manufacturer or local representative regarding attachments to structures or details.

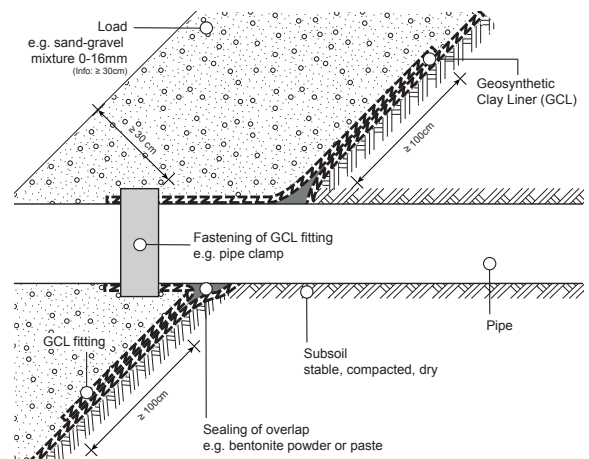

Fig. 15
Typical penetration detail

19. Cover Placement

19.1 In all cases it is required that the responsible designer approves the slope stability analysis of the system.

19.2 Cover soils shall be free of sharp-edged stones or other foreign matter that could damage the GCL. Cover soils should be an approved material with respect to particle size uniformity, moisture content, and chemical compatibility. Recommended cover soils typically have a wellgraded particle size distribution ranging between fines and 25mm.

Soils with greater than 50% of material (by weight) larger than 20mm may require a field-scale test using the proposed subgrade surface, cover soil, and placement and compaction equipment.

19.3 Placement of sandy soils over Bentofix® should be preferred.

19.4 Soils can be placed on top of Bentofix® if the bentonite moisture content is less than 50%.

19.5 Soil cover shall be placed over the GCL using construction equipment that minimizes stresses on Bentofix®. In any case a minimum of 300mm of cover shall be maintained between the equipment tires/tracks and the GCL at all times during the covering process (Fig. 16).

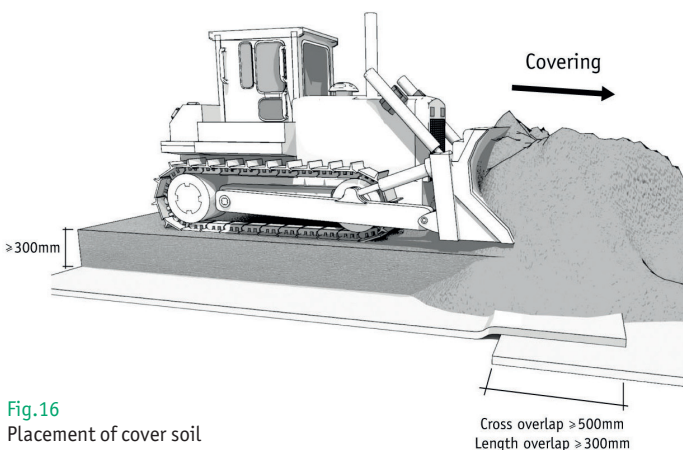

19.6 Frequent traffic can be run over a soil coverage of at least 800mm. Differing thickness or soil material might be possible due to site conditions and soils. In this case please contact NAUE or their local representative.

19.7 Soil cover should be placed on Bentofix® by carefully pushing the soil on top of the GCL (Fig. 16), without causing any damage and in a manner that prevents the soil from entering the GCL overlap zones.

19.8 To prevent overlaps being separated during soil placement, it is possible to manually place soil on top of the overlaps.

19.9 When another geosynthetic material is placed over the GCL, care must be taken to avoid using equipment and construction practices that could damage the GCL.

19.10 Typically the 300mm cover soil should also be placed directly on top of the geosynthetic material (see 19.9), prior to any bentonite hydration over 50% moisture content.

19.11 After placement of the minimum 300mm thick cover soil layer over a Bentofix® roll as a single sealing system, the final cover soil thickness should be placed in less

20. Interruptions during Installation

20.1 Uncovered areas should be protected at the edges overnight with a plastic membrane (figure 10) to prevent bentonite hydration.

20.2 In the event of rainfall, which could cause a prehydration of the bentonite portion of the unconfined GCL of more than 50%, a temporary cover consisting of a waterproof tarpaulin or plastic sheet to protect the GCL should be placed over the GCL.

20.3 The edges of exposed sheets should be weighted down with sandbags or equivalent ballast, which does not cause any damage to the GCL, to prevent uplift in the event of strong winds.

21. Repairs

21.1 In the event that an area of Bentofix® GCL becomes damaged, torn or punctured during installation, the affected area should be repaired.

21.2 On relatively level surfaces, the damaged area should be covered with a separate piece of Bentofix® GCL extending at least 500mm beyond the damaged area in every direction (Fig. 17).

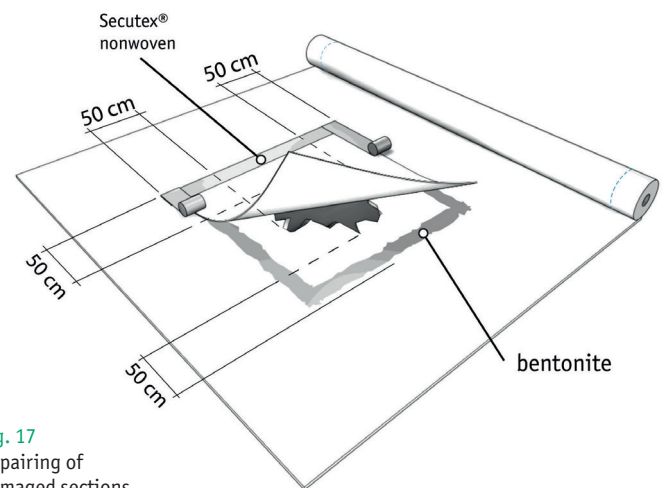

21.3 Damaged GCL material on slopes shall be repaired by the same procedures as described in section 21.2 and 21.3. Additionally it should be ensured that the slope stability is not endangered.

21.4 Care must be taken during the placement of cover materials to ensure that the patch is not displaced.

21.5 Areas that are exposed to standing water or excess precipitation with resulting excessive bentonite hydration ($\geq 50\%$) prior to soil covering should be examined for damage by subsequent activities. If it is determined that the GCL has been hydrated and damaged, the GCL should be covered with a new GCL piece over the affected area or removed and replaced.

21.6 All Bentofix® GCLs where bentonite was exposed to hydrocarbon fuels, chemicals, non-compatible liquids or other harmful liquids during the installation should be removed and replaced with non-affected Bentofix® GCL.

22. Inspection

22.1 After deployment and seaming, a close visual inspection of the Bentofix® GCL rolls and seams shall be made by the project engineer or an approved person. This is done as soon as possible after deployment has been completed.

22.2 The inspection should include overlaps, alignments, penetrations, connections, detections of any defects, including installation damage. Detected falsely installed areas shall be marked, repaired and the repairs shall be inspected and approved by the project engineer or an approved person.

22.3 This inspection/repair process is to be carried out in a systematic manner as soon as possible to ensure that no defective area stays unrepaired.

22.4 Once the inspection has passed the next layer of geosynthetics may be installed or the spreading of the cover soil can begin in a method not harmful to the installed GCL.

23. Hydration of Bentonite

23.1 In cases where the containment of non-aqueous liquids is required, it may be necessary to hydrate the covered GCL with water prior to use.

23.2 If necessary prehydration may be accomplished (provided that the clay component of the GCL is covered by permeable materials) by introducing water into the containment area, either by flooding or by the use of sprinklers. NAUE GmbH & Co. KG or their local representative should be contacted for specific procedures if manual hydration is necessary.

24. Special Conditions

For other specific procedures contact a NAUE representative.



NAUE GmbH & Co. KG
Gewerbestr. 2
32339 Espelkamp
Germany

Phone +49 5743 41-0
Fax +49 5743 41-240
info@naue.com
www.naue.com



Installation Briefing

practical theoretical

1. Name of site: _____

2. Date: _____ Time from: _____ to: _____

3. Product-type: _____

Visual inspection of geosynthetic: _____

4. Contractor: Company: _____

Name: _____

Tel.: _____ Fax.: _____

Email: _____

5. Installer: Company: _____

Name: _____

Tel.: _____ Fax.: _____

Email: _____

6. Weather:

Temperature: _____ sunny cloudy Rain/Snow light
 medium
 strong

7. Installation guideline available on construction site: yes no

Status of guideline: _____

8. Subbase condition (view of NAUE): _____

9. Contractor/installer informed on placement of cover material:

Type of cover/geosynthetic material min. thickness of cover Direction of placement

Direction of spreading Overlapping Geosynthetic storage area

10. Photo documentation: yes no GPS position _____

Fotos filed: yes no File location _____ Marked in installation plan: yes no

11. Notes on additional pages: yes no _____

12. Confirmation of briefing:

Name: _____

Name: _____

Company: NAUE GmbH & Co. KG

Company: _____

Date, signed: _____

Date, signed: _____



NAUE GmbH & Co. KG
 Gewerbestrasse 2
 32339 Espelkamp-Fiestel
 Germany

Phone +49 5743 41-0
 Fax +49 5743 41-240
 E-Mail info@naue.com
 Internet www.naue.com



is a registered trademark of NAUE GmbH & Co. KG.

The information contained herein is the best to our knowledge, true and accurate. There is no implied or expressed warranty.
 © 2011 by NAUE GmbH & Co. KG, Espelkamp-Fiestel, Germany · All rights reserved. · No. F 3 · Status 27.06.2011

Bentofix® unloading

Status and No. of installation guideline

Date	Roll Nr.	Weather	Damages	Fixed	Comments	Name symbol
			<input type="checkbox"/> YES <input type="checkbox"/> NO	<input type="checkbox"/> YES <input type="checkbox"/> NO		
			<input type="checkbox"/> YES <input type="checkbox"/> NO	<input type="checkbox"/> YES <input type="checkbox"/> NO		
			<input type="checkbox"/> YES <input type="checkbox"/> NO	<input type="checkbox"/> YES <input type="checkbox"/> NO		
			<input type="checkbox"/> YES <input type="checkbox"/> NO	<input type="checkbox"/> YES <input type="checkbox"/> NO		
			<input type="checkbox"/> YES <input type="checkbox"/> NO	<input type="checkbox"/> YES <input type="checkbox"/> NO		
			<input type="checkbox"/> YES <input type="checkbox"/> NO	<input type="checkbox"/> YES <input type="checkbox"/> NO		
			<input type="checkbox"/> YES <input type="checkbox"/> NO	<input type="checkbox"/> YES <input type="checkbox"/> NO		
			<input type="checkbox"/> YES <input type="checkbox"/> NO	<input type="checkbox"/> YES <input type="checkbox"/> NO		
			<input type="checkbox"/> YES <input type="checkbox"/> NO	<input type="checkbox"/> YES <input type="checkbox"/> NO		
			<input type="checkbox"/> YES <input type="checkbox"/> NO	<input type="checkbox"/> YES <input type="checkbox"/> NO		
			<input type="checkbox"/> YES <input type="checkbox"/> NO	<input type="checkbox"/> YES <input type="checkbox"/> NO		
			<input type="checkbox"/> YES <input type="checkbox"/> NO	<input type="checkbox"/> YES <input type="checkbox"/> NO		
			<input type="checkbox"/> YES <input type="checkbox"/> NO	<input type="checkbox"/> YES <input type="checkbox"/> NO		
			<input type="checkbox"/> YES <input type="checkbox"/> NO	<input type="checkbox"/> YES <input type="checkbox"/> NO		
			<input type="checkbox"/> YES <input type="checkbox"/> NO	<input type="checkbox"/> YES <input type="checkbox"/> NO		
			<input type="checkbox"/> YES <input type="checkbox"/> NO	<input type="checkbox"/> YES <input type="checkbox"/> NO		
			<input type="checkbox"/> YES <input type="checkbox"/> NO	<input type="checkbox"/> YES <input type="checkbox"/> NO		
			<input type="checkbox"/> YES <input type="checkbox"/> NO	<input type="checkbox"/> YES <input type="checkbox"/> NO		
			<input type="checkbox"/> YES <input type="checkbox"/> NO	<input type="checkbox"/> YES <input type="checkbox"/> NO		
			<input type="checkbox"/> YES <input type="checkbox"/> NO	<input type="checkbox"/> YES <input type="checkbox"/> NO		
			<input type="checkbox"/> YES <input type="checkbox"/> NO	<input type="checkbox"/> YES <input type="checkbox"/> NO		

Onsite storage according to chapter 9 of Bentofix® installation guidelines YES NO

Comments

Name symbol

Name symbol	Name	Company



Bentofix® installation Typ

Status and No. of installation guideline

Date	Roll Nr.	Weather	Overlap checked	Chapter 1 - 24 followed	Differences /comments	Name symbol
			<input type="checkbox"/> YES <input type="checkbox"/> NO	<input type="checkbox"/> YES <input type="checkbox"/> NO		
			<input type="checkbox"/> YES <input type="checkbox"/> NO	<input type="checkbox"/> YES <input type="checkbox"/> NO		
			<input type="checkbox"/> YES <input type="checkbox"/> NO	<input type="checkbox"/> YES <input type="checkbox"/> NO		
			<input type="checkbox"/> YES <input type="checkbox"/> NO	<input type="checkbox"/> YES <input type="checkbox"/> NO		
			<input type="checkbox"/> YES <input type="checkbox"/> NO	<input type="checkbox"/> YES <input type="checkbox"/> NO		
			<input type="checkbox"/> YES <input type="checkbox"/> NO	<input type="checkbox"/> YES <input type="checkbox"/> NO		
			<input type="checkbox"/> YES <input type="checkbox"/> NO	<input type="checkbox"/> YES <input type="checkbox"/> NO		
			<input type="checkbox"/> YES <input type="checkbox"/> NO	<input type="checkbox"/> YES <input type="checkbox"/> NO		
			<input type="checkbox"/> YES <input type="checkbox"/> NO	<input type="checkbox"/> YES <input type="checkbox"/> NO		
			<input type="checkbox"/> YES <input type="checkbox"/> NO	<input type="checkbox"/> YES <input type="checkbox"/> NO		
			<input type="checkbox"/> YES <input type="checkbox"/> NO	<input type="checkbox"/> YES <input type="checkbox"/> NO		
			<input type="checkbox"/> YES <input type="checkbox"/> NO	<input type="checkbox"/> YES <input type="checkbox"/> NO		
			<input type="checkbox"/> YES <input type="checkbox"/> NO	<input type="checkbox"/> YES <input type="checkbox"/> NO		
			<input type="checkbox"/> YES <input type="checkbox"/> NO	<input type="checkbox"/> YES <input type="checkbox"/> NO		
			<input type="checkbox"/> YES <input type="checkbox"/> NO	<input type="checkbox"/> YES <input type="checkbox"/> NO		
			<input type="checkbox"/> YES <input type="checkbox"/> NO	<input type="checkbox"/> YES <input type="checkbox"/> NO		
			<input type="checkbox"/> YES <input type="checkbox"/> NO	<input type="checkbox"/> YES <input type="checkbox"/> NO		
			<input type="checkbox"/> YES <input type="checkbox"/> NO	<input type="checkbox"/> YES <input type="checkbox"/> NO		
			<input type="checkbox"/> YES <input type="checkbox"/> NO	<input type="checkbox"/> YES <input type="checkbox"/> NO		
			<input type="checkbox"/> YES <input type="checkbox"/> NO	<input type="checkbox"/> YES <input type="checkbox"/> NO		
			<input type="checkbox"/> YES <input type="checkbox"/> NO	<input type="checkbox"/> YES <input type="checkbox"/> NO		

Name symbol	Name	Company

NAUE and Bentofix® are registered trademarks of NAUE GmbH & Co. KG in various countries. The information contained herein is to the best of our knowledge, true and accurate. There is no implied or expressed warranty.



NAUE GmbH & Co. KG
 Gewerbestr. 2
 32339 Espelkamp-Fiestel
 Germany

Phone +49 5743 41-0
 Fax +49 5743 41-240
 info@naue.com
 www.naue.com