

Manufactured
in New Zealand

Composite Bolts and Soil Nails

Precision machined threads with
advanced composite materials

- Designed for maximum shear strength as the most important characteristic
- Tested to ASTM standards for optimal quality and safety
- Highly durable
- Lightweight
- Easy to install and cut on-site
- Corrosion-free

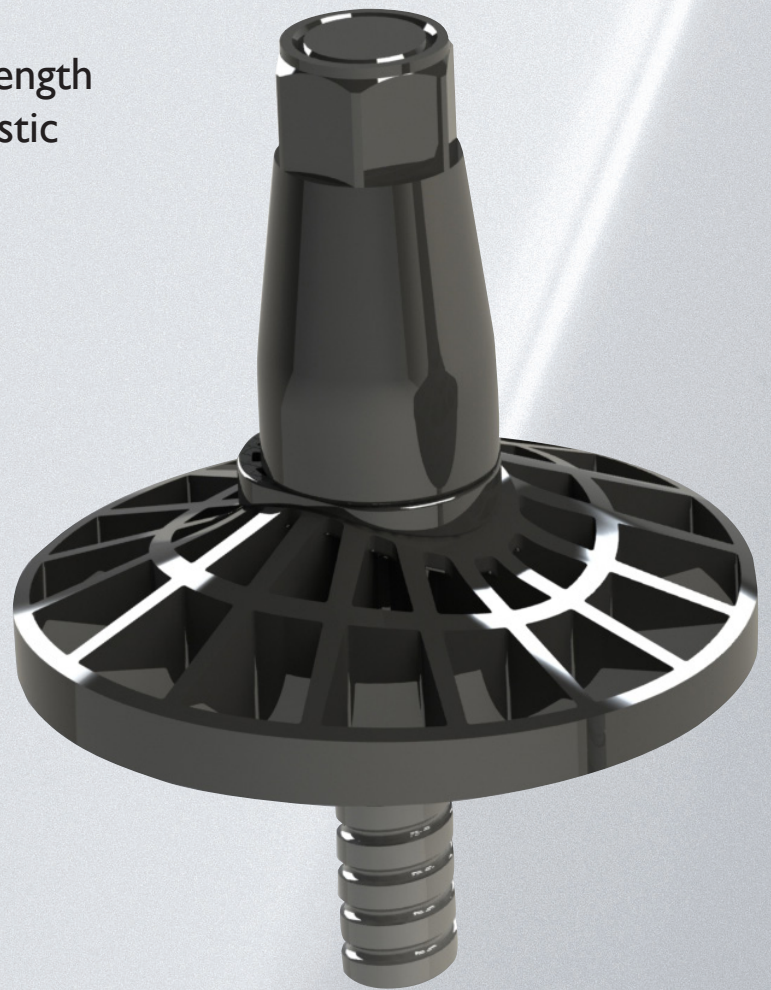

TRUST IN PULTRON BECAUSE THE WORLD DOES
+64 6 867 8582 | info@pultron.com | pultron.com

pultron[®]
COMPOSITES

Advantages

- Corrosion-free
- Non-magnetic
- Non-conductive
- High strength
- Lightweight
- Cutable bolts for ground support
- NATM/SEM/Lunardi Tunneling method ground support
- Bolting or soil-nailing in most ground conditions including corrosive environments as an alternative to black, galvanised or epoxy-coated steel, stainless steel or double-corrosion protected bolts
- No risk of damage to Tunnel Boring Machines



Technical Data

Lengths: 6 metre or 12 metre (custom lengths on request)

Washers: standard or high strength

Guaranteed Properties			
Size	25mm	32mm	32mm Hollow
Ultimate Tensile Strength	>280kN	>430kN	>340kN
Shear (single sided)	>78kN	>113kN	>90kN
Shear (double sided)	>156kN	>226kN	>180kN
Nut Termination	>100kN	>140kN	>140kN
Working Area	385mm ²	645mm ²	532mm ²
Elastic Modulus*	>53GPa	>53GPa	>53GPa

*Elastic Modulus is based on the working area of the bolt

All bolts products have been tested according to ASTM methods.

Properties as presented are guaranteed values. Appropriate factors of safety must be applied to determine safe working limits.

Pultron products are sold subject to Pultron's standard warranty and nothing here in shall expand or extend such warranty. The data contained herein is considered representative of present production and believed to be reliable. Pultron Composites Limited reserves the right to make improvements in the product and process which may result in benefits and/or changes to some physical and mechanical properties.

Get in touch

Discover the benefits of using composite bolts and soil nails on your next project

New Zealand/Pacific Islands Distributor

Chris Brockliss: 021 270 3139 | chrisbrockliss@gpil.co.nz

TRUST IN PULTRON BECAUSE THE WORLD DOES

+64 6 867 8582 | info@pultron.com | pultron.com

pultron[®]
COMPOSITES